



Adobe

Tips
Tricks
Techniques

Adobe
InDesign 2



By Tim Cole

getting the most out of guides

If you're used to other layout applications, you may be unaware of all the things you can do with ruler guides in InDesign. If you use guides in your work (if you're not you should), then read on.

In this tip you will learn:

- how to position, align, lock and color individual ruler guides
- how to snap guides to objects
- how to snap guides to rulers
- using Copy and Paste with guides
- using Step and Repeat with guides
- how use InDesign's Align palette with ruler guides
- how to color-code your guides
- how to lock individual guides
- how to manage guides with layers
- how to use InDesign's Create Guides feature
- how to use guides in libraries

(To jump back to this TOC, click on the title line of each page)

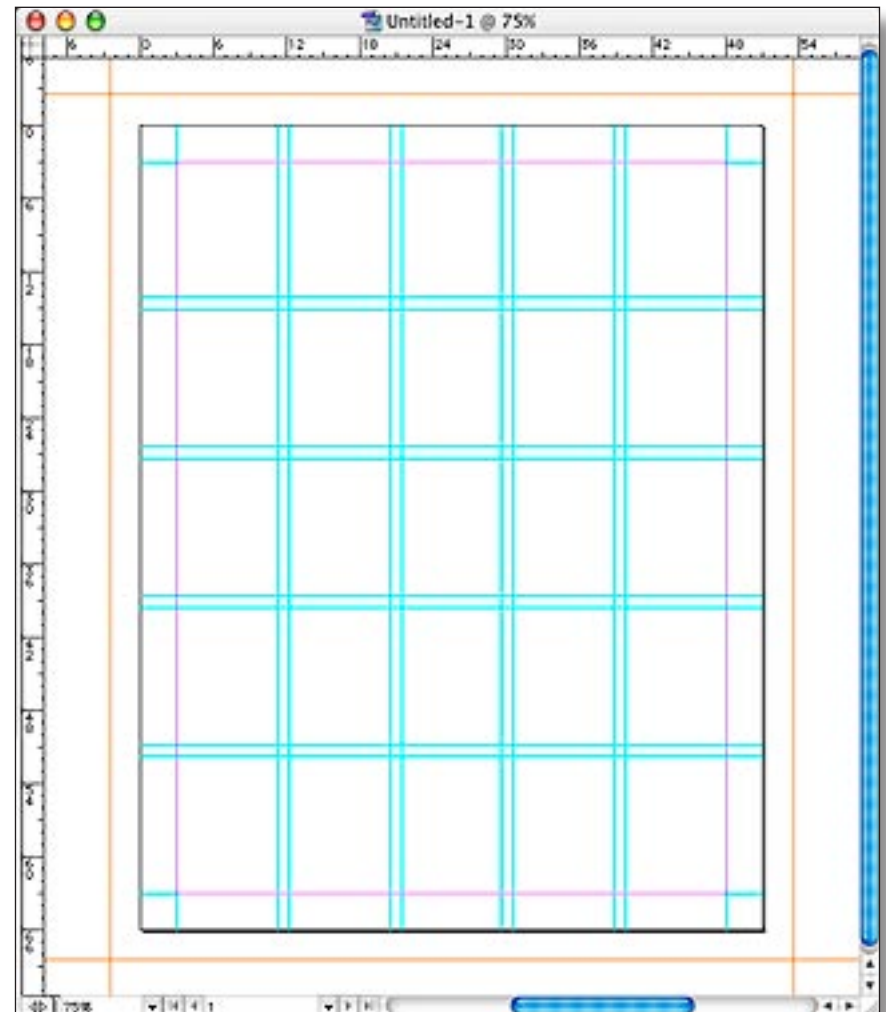

controlling ruler guides: numeric positioning

Have you ever wished you numerically control the position of a ruler guide? In InDesign you can do exactly that.

1. Use any tool to click on your horizontal or vertical ruler to drag out a ruler guide. With the guide still selected, note that either the X or Y coordinate will display in the **Transform** palette.
2. With the ruler guide selected, enter different values in the Transform palette and note that in InDesign you can control the position of a ruler guide numerically, not by just by dragging and dropping the guide. This feature gives you much greater levels of precision and control over the positioning of your ruler guides.

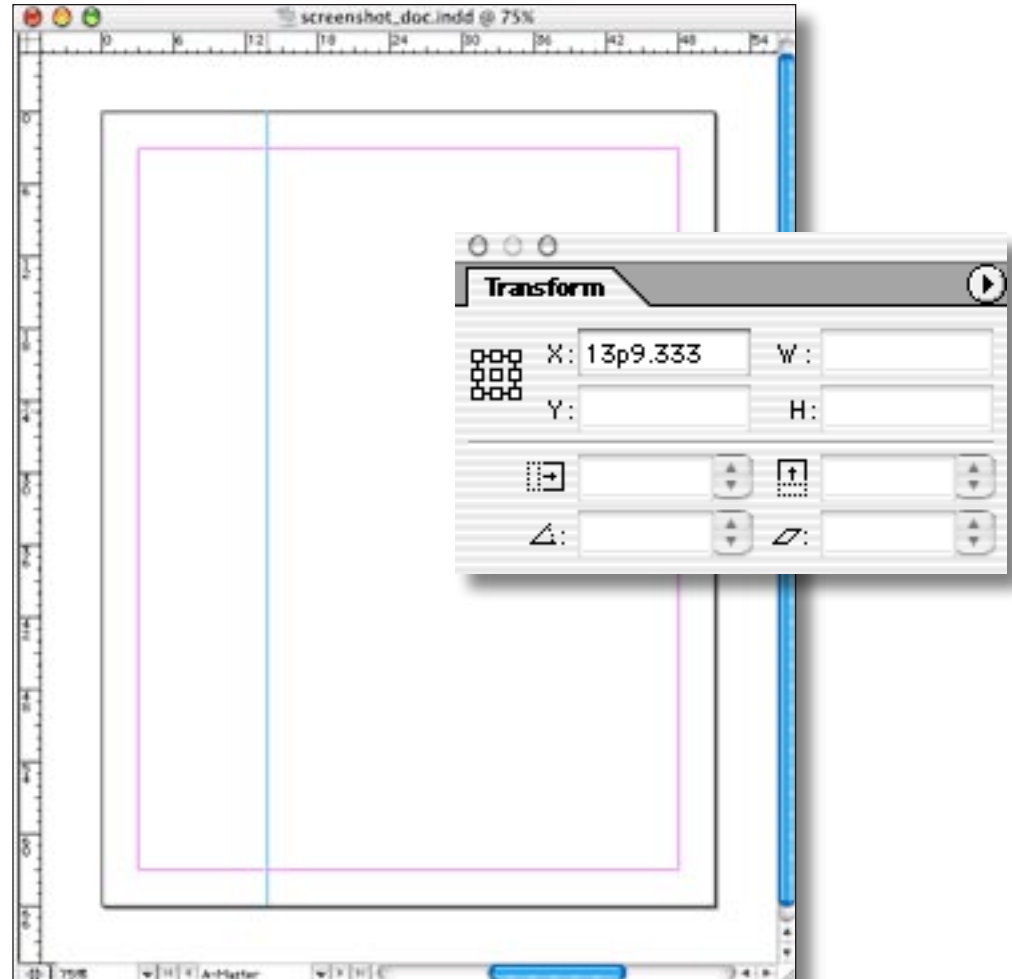

controlling ruler guides: snapping to objects

Have you ever wished you had a quick way to snap a ruler guide *exactly* to the edge of an object on your page? Check out this little shortcut in InDesign.

1. Select the object to which you'd like to snap the ruler guide with the selection tool.



2. When you drag out a ruler guide, drag the two-headed cursor over one of the selected object's handles. This will snap the ruler guide exactly to the edge of the frame. There's no need to zoom into 4000% to verify that the guide is positioned correctly.

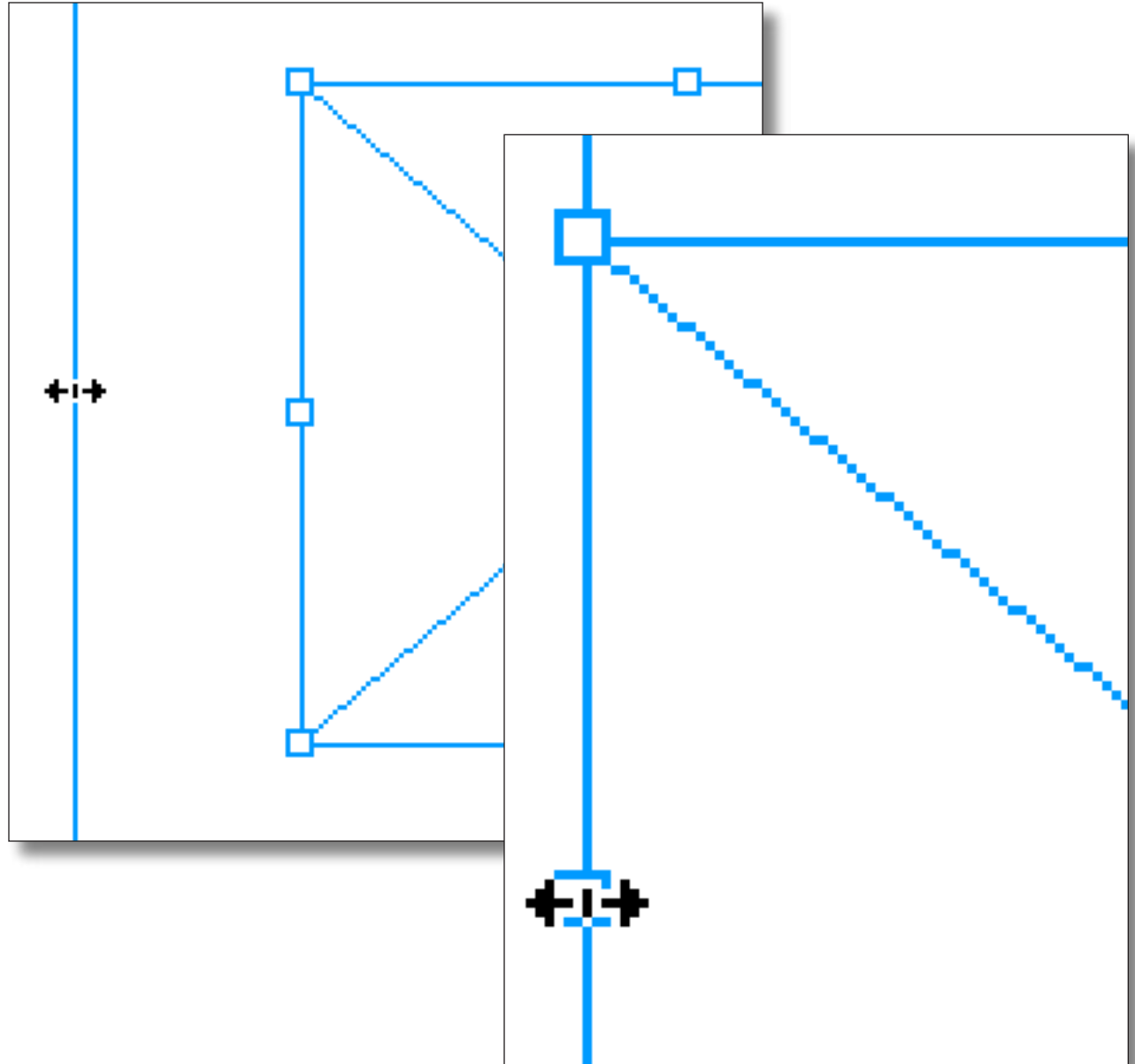

controlling ruler guides: snapping to ruler ticks

Have you ever wished you had a quick way to snap a ruler guide *exactly* to a specific tick mark on your horizontal or vertical ruler?

1. Hold down the **Shift** key when you drag a ruler guide. Notice that it snaps to the ticks on the horizontal or vertical ruler. When you release the Shift key, the guide reverts back to the default behavior and doesn't snap to the ruler ticks.

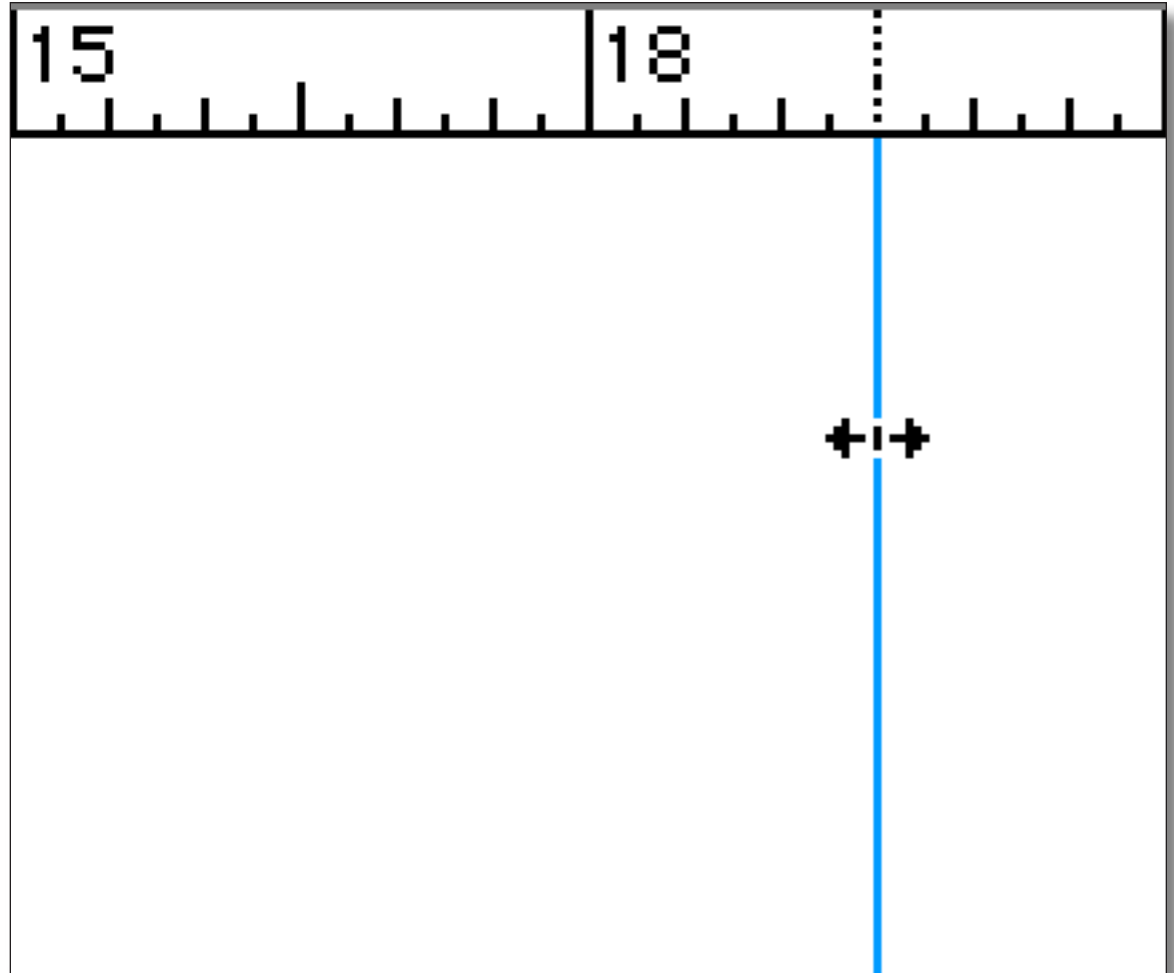

controlling ruler guides: copy and paste

Have you ever wished you had a quick way to duplicate a set of guides on a different page or in a different document? In InDesign, ruler guides are objects that you can copy and paste using the Clipboard.

1. Suppose you've created bleed guides out on your pasteboard on one spread and you'd like to have those same guides in another. One way to do this is to select the bleed guides you've created (more on fast, easy ways to do this later in this tip document), and use the **Edit > Copy** command.



2. Switch to the target spread in the same or different document, and use **Edit > Paste** to paste the ruler guides into the same position they had in the source spread.

Note that if you're pasting guides into another document, the target spread needs to have same page dimensions in order for the original guide positioning to be maintained.

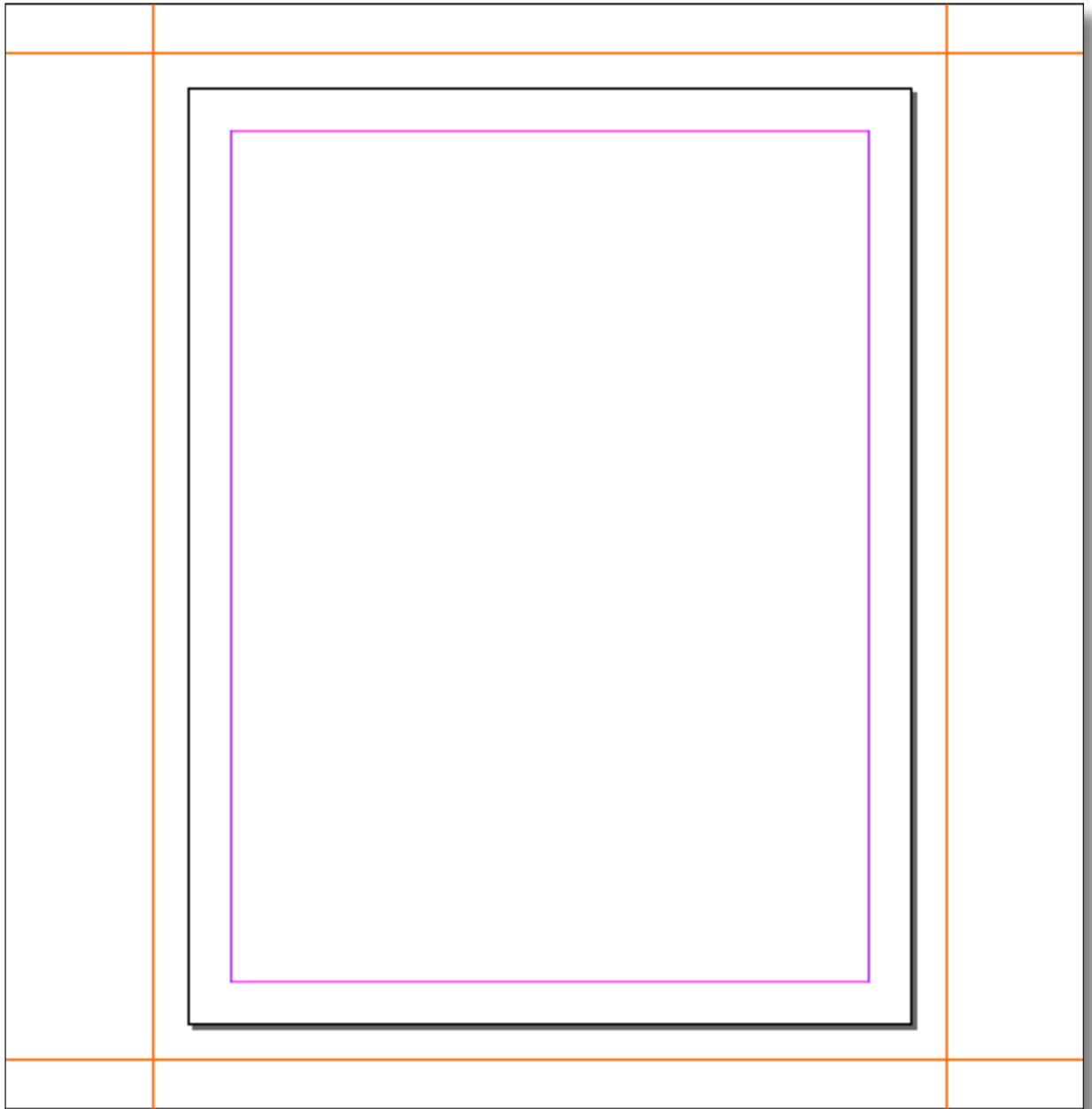

controlling ruler guides: step and repeat

Have you ever wished you had a quick way to create multiple guides with a fixed offset? Not only can you copy and paste ruler guides in InDesign, you can also use the Step and Repeat command, just like you would with any other object.

1. Drag a ruler guide on to your page.
2. With the guide still selected, go to **Edit > Step and Repeat**. You can then specify the number of guides you want to create as well as the horizontal or vertical offset desired.

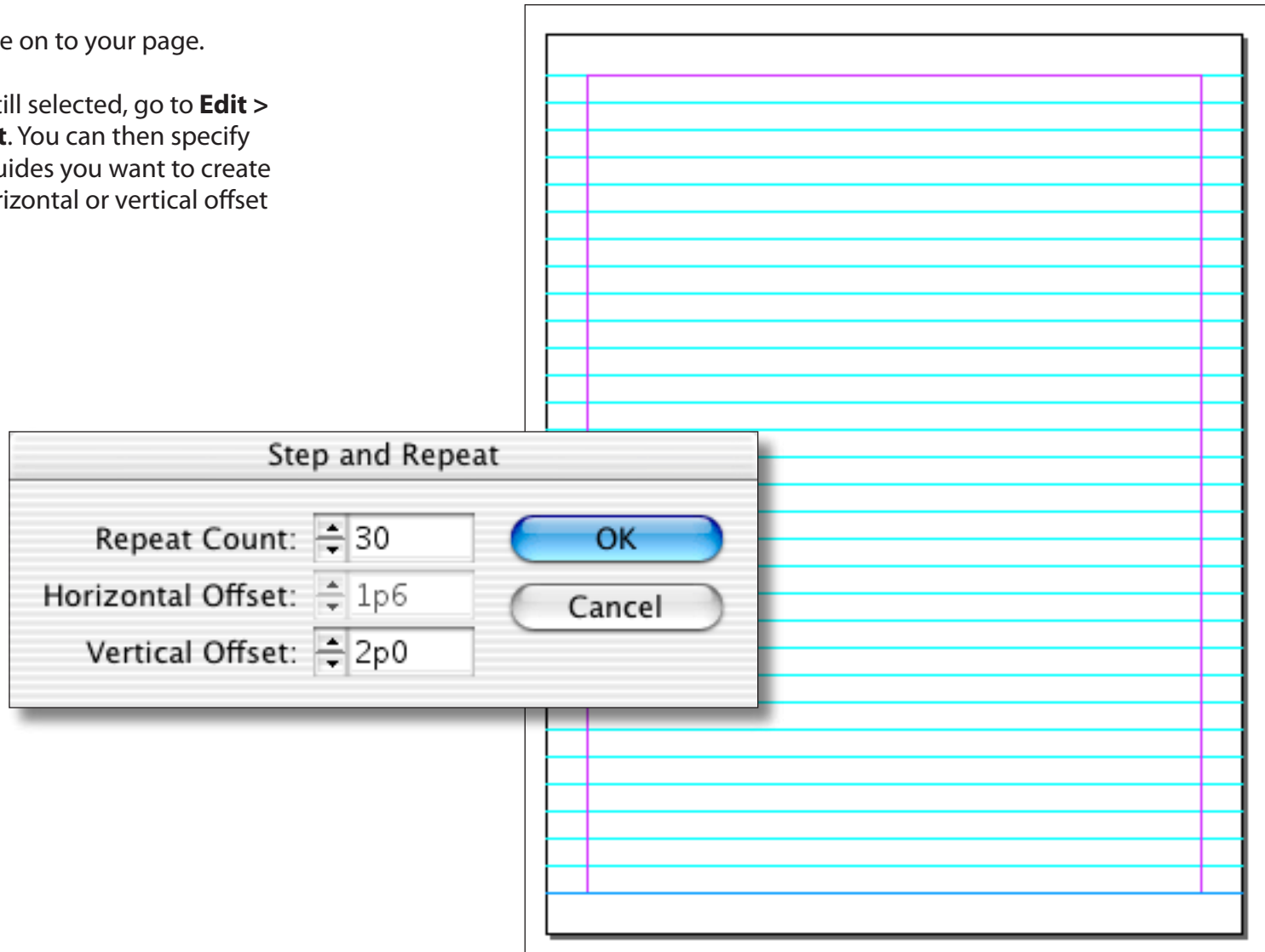

controlling ruler guides: using the Align palette

Have you ever needed to distribute ruler guides in order to divide an area of your page into sections? InDesign enables you to do just that.

Suppose you'd like to arrange some graphics in a manner similar to the example in the screen shot below. In InDesign it's easy to set up ruler guides to enable you to size and position the four image frames quickly and accurately.



Velis nummolor suscollamet wissi. Sit num in ulputpat dolorero conulput nullut in eugait prat. Ut vulpute feu faccum acilisci eumsan eugueriure tat. Duipisisi.

Tis dunt ipit, consecte tin ullaor iriure modiam quisi. Wis do dip ea autat vulla feuis non velissi estrud do delit eliscidui et, sed enim alit aliquat, sectem nos nulla consed mincidunt nim dolore con et venim ad del irilis nullaoret nullan hendigna feuis dio consecte cortio consectem vulput dolutat wis dionsequam, si erosto od dunt prat, senit prat, consectet luptatem ilis nulluptatis acipit verat. Ut nonnulla feugue consed dolore commolor susci tet ut inim adit iuscip eumsan ex eugiamconsed modolor eetumsan estie vel dolor sum zzrit incilissi.

Rud dolorperatem nim quis nos am dunt er susci blandipsummy nulla consenim volor amcommy nibh exerill andipsum adit dolor inis alisi enim et illan henim digna atie modigna corem dolore minibh ex ex eummodiam niat nis do elit, sed tatis am in ulputpatet ipsummo dolorper sum in et iuscidunt velismolore tatisim quat vulan ex et accum esse tatio conum ipsustie dio core erosio nsequismod er sim quipsum eros acipit verostinim

controlling ruler guides: using the Align palette

1. Drag the appropriate number of ruler guides on your page.

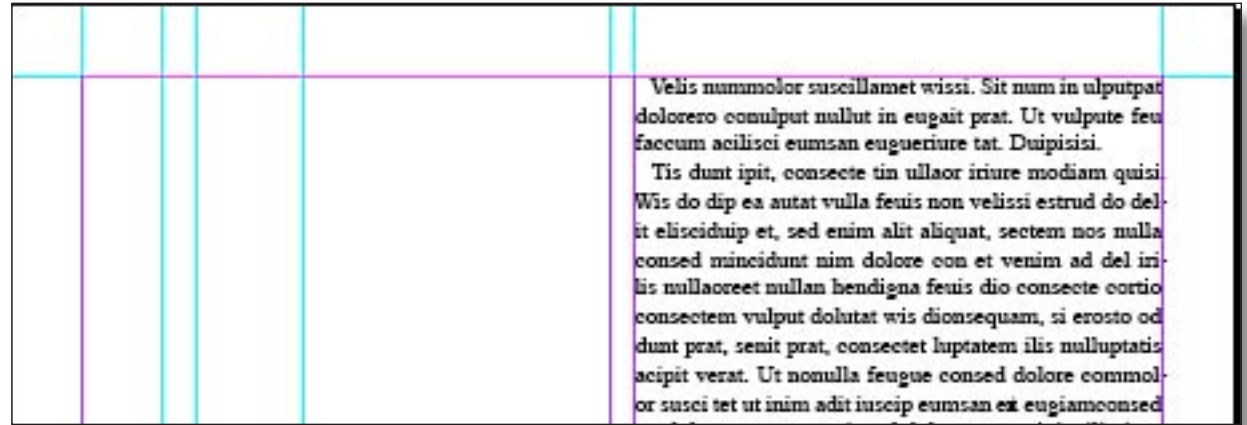

2. Select the ruler guides, and then distribute them using the buttons on the Align palette.

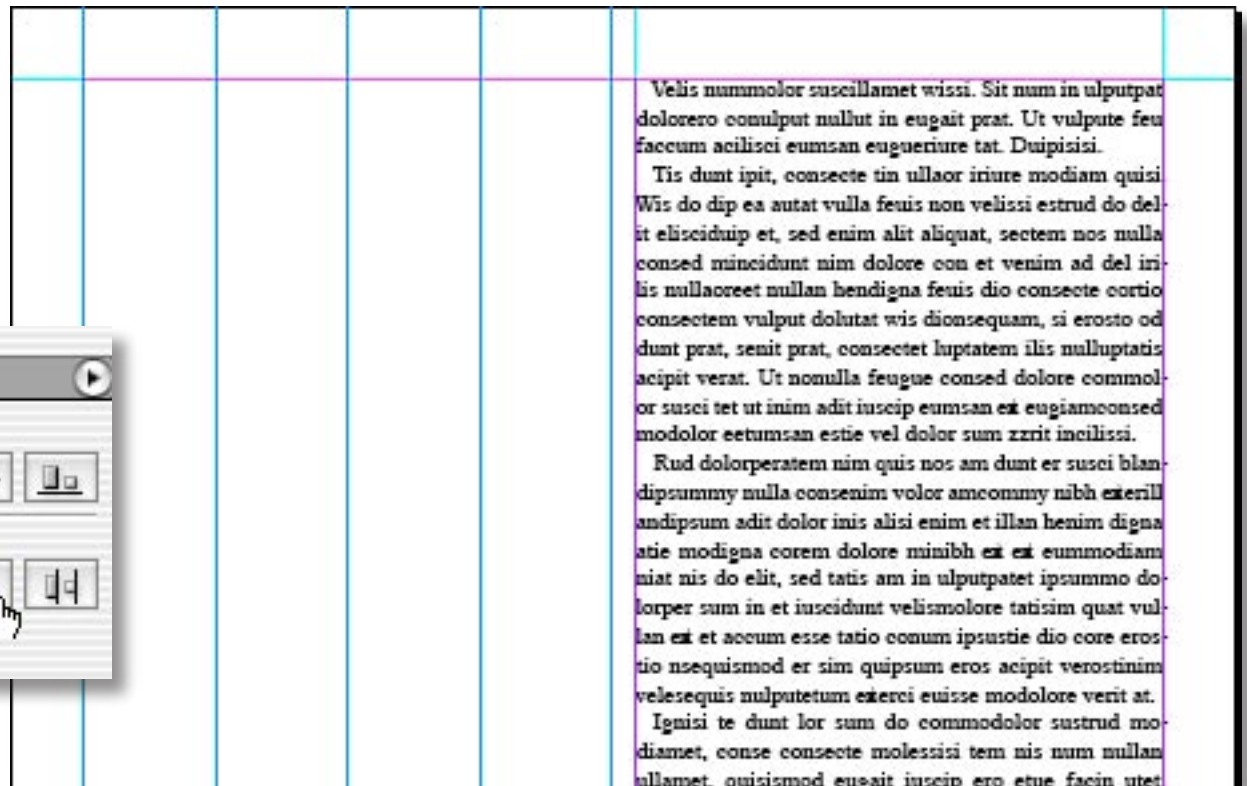
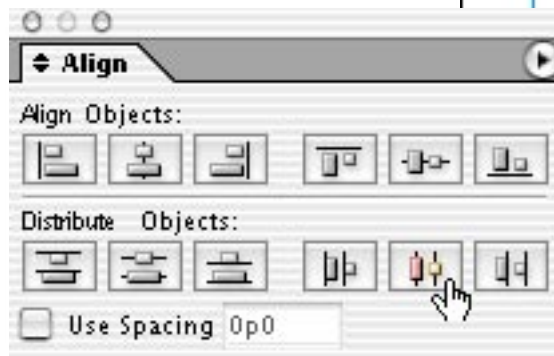

color-coding your ruler guides

Most of us create different guides to do different things. We might create bleed guides, a page grid, and another set of guides to position objects that aren't snapped to the page grid. Wouldn't it be nice if you could color-code your ruler guides in order to visually identify which guides do what job? In InDesign you can do just that. You can assign different colors to your guides on a guide

1. Select the ruler guides to which you wish to assign a new display color.
2. Use **Layout > Ruler Guides** or the **contextual menu** to get to the **Ruler Guides** dialog box. There you can select the color you want for your ruler guides.

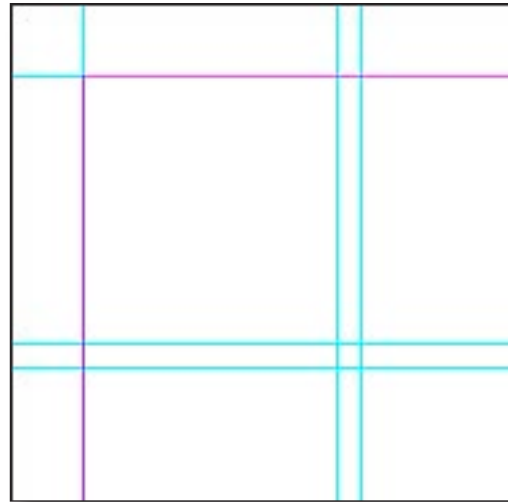

before: all the guides look the same

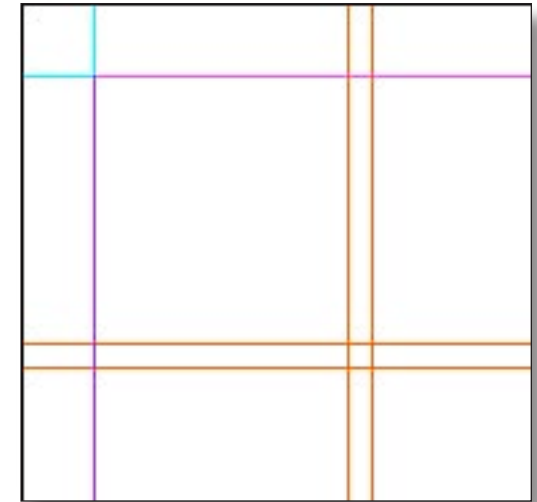

after: different colors for different functions

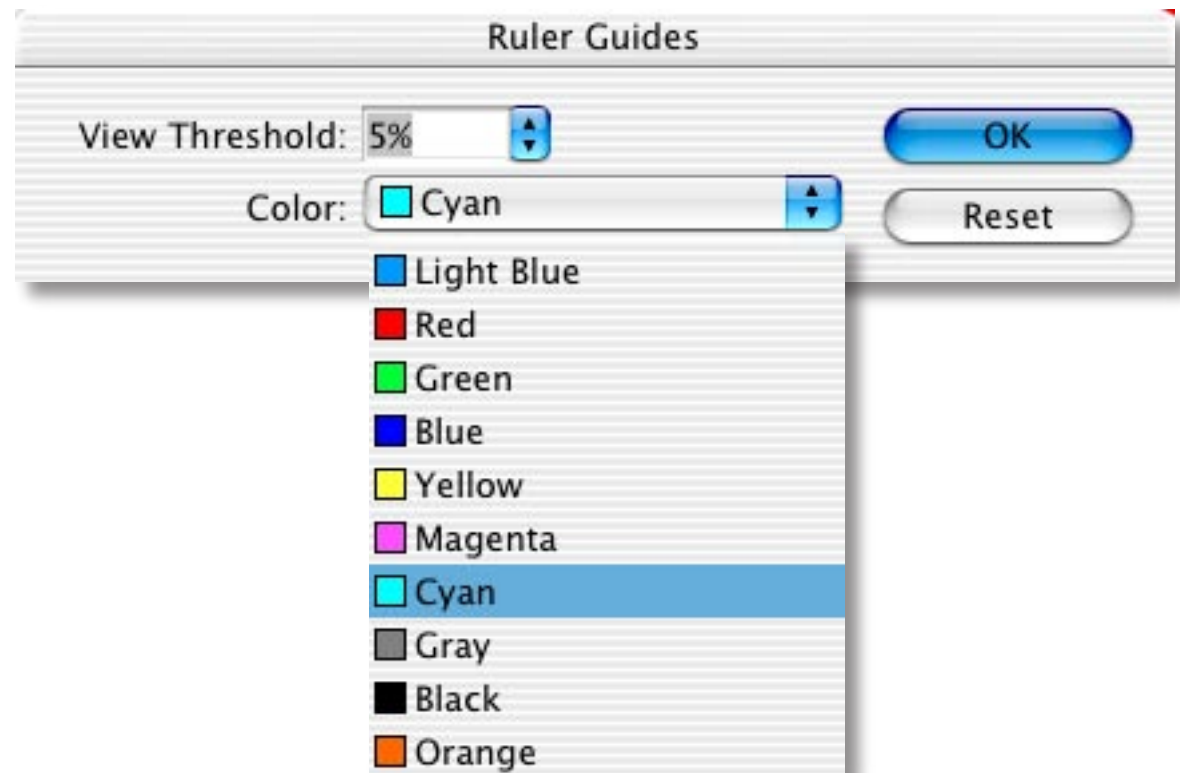

locking individual ruler guides

You're probably used to having to either lock the position of either all or non of your ruler guides. InDesign gives you the flexibility of locking down your guides on a guide-by-guide basis, so that it's not an all or nothing choice that you have to make in every situation

1. Locking any selected guide(s) is just like locking the position of any other object in InDesign. Select the guide(s) you'd like to lock and then use the **Object > Lock Position** command.

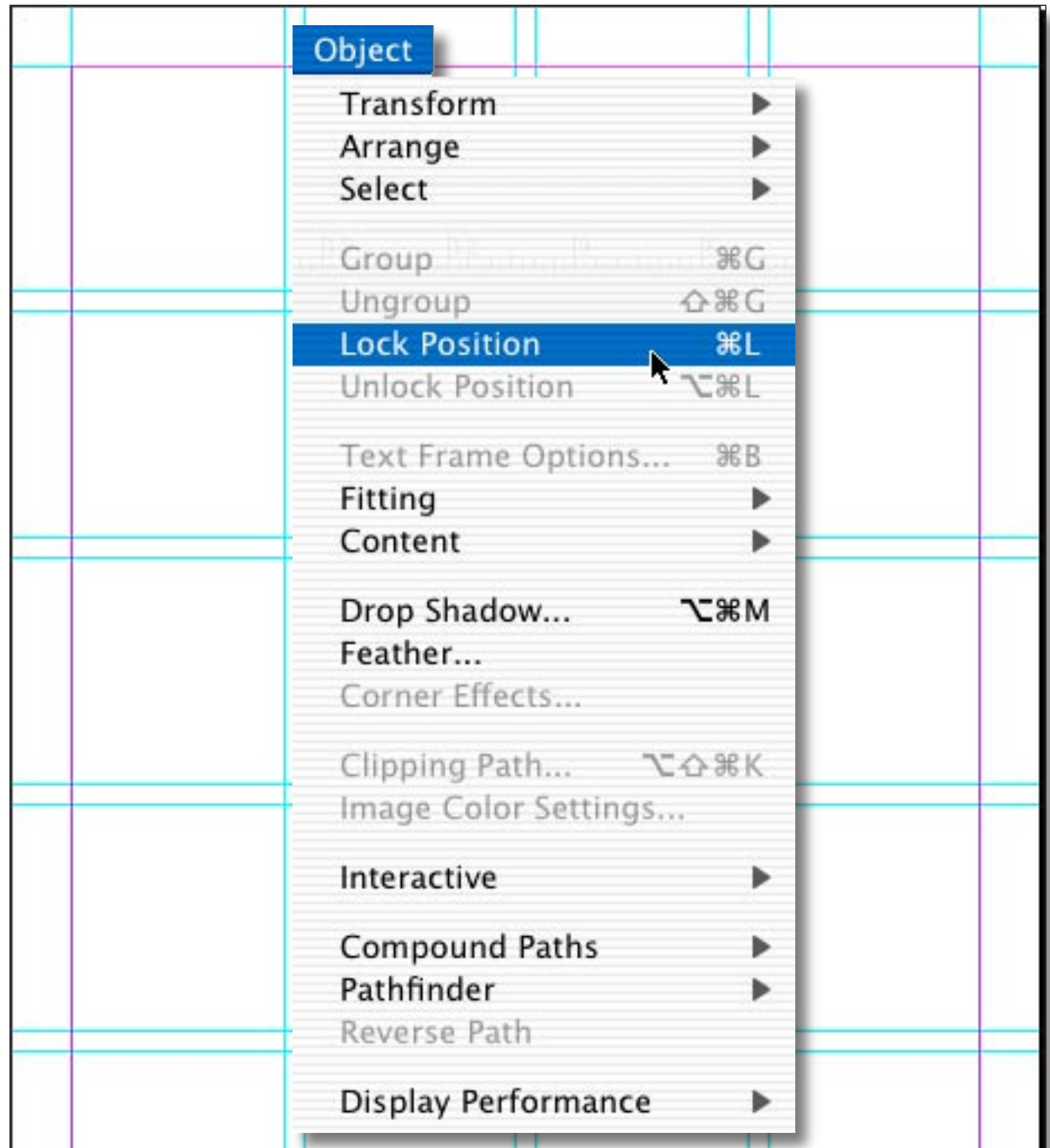

managing ruler guides with layers

Once you've created and assigned colors to all your guides, there is another thing that InDesign can do for you to make working with ruler guides more efficient and more powerful. In InDesign you can assign ruler guides to different layers and then take advantage of the locking and visibility features.

1. Like any other object in InDesign, when you create an object in InDesign, it gets assigned to the active layer.
2. Also just like any other object. You can move selected guides from layer to layer. Click on the square object proxy in the later palette and drag it to the layer to which you desire to move the object.
3. Once you've got your ruler guides segregated to their desired layers, you can use each layer's visibility toggle to choose which sets of guides you want to see/use at any given time, without being distracted or confused by other guides you don't need at the time. If you typically use a lot of ruler guides in your layout, this can be a major benefit.
4. You can also lock ruler guides on a layer by layer basis easily by using the layer's locking toggle switch. This way you can quickly lock down some sets of guides, but keep some sets editable and adjustable.

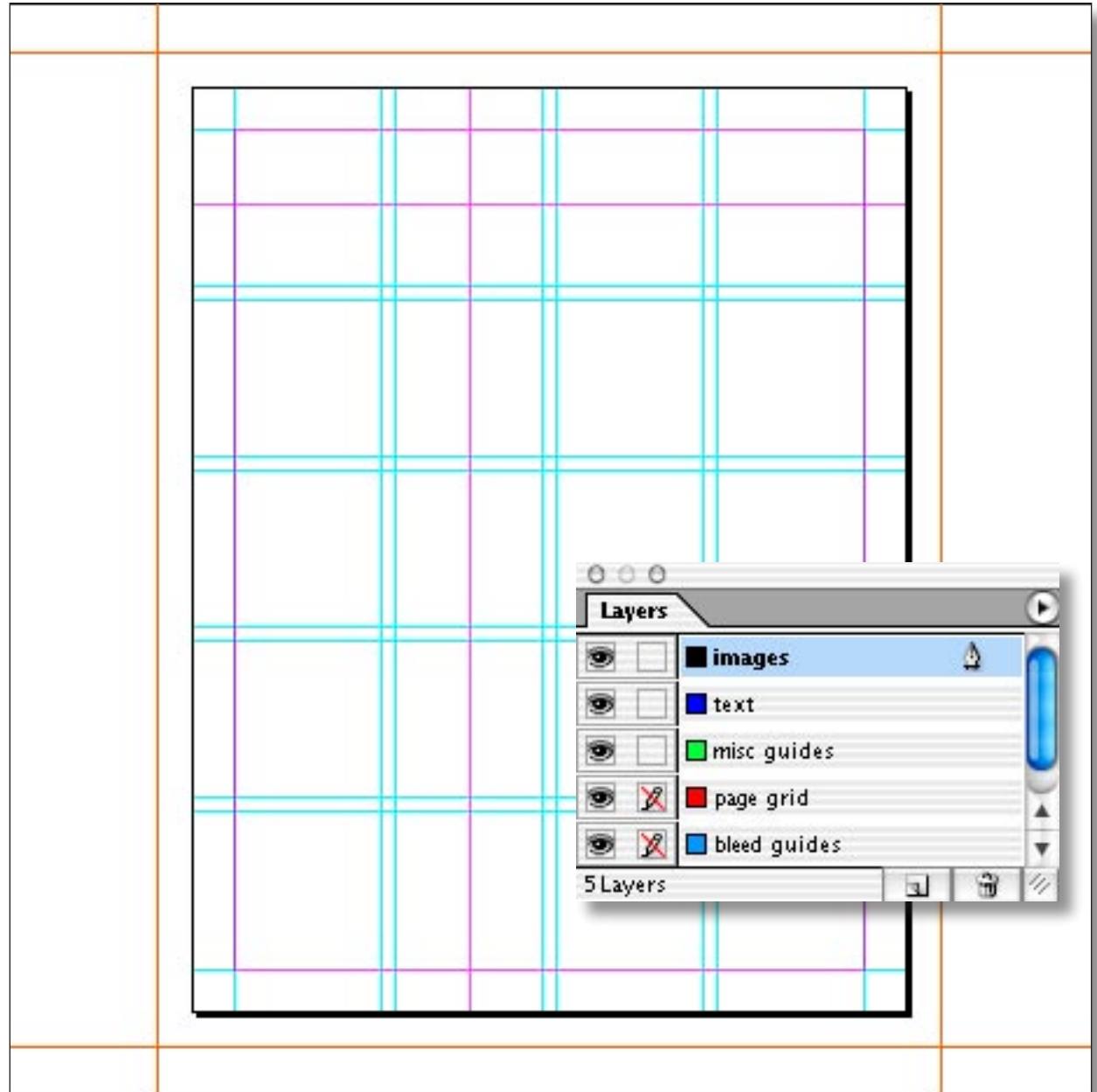

using the Create Guides feature

InDesign makes it easy for you to quickly create page grids for your documents. The Create Guides feature enables you to easily divide either the entire page area or the area within margins into rows and columns with user definable gutters. Different grids can live on different layers in your document or

1. **Layout > Create Guides** takes you to the Create Guides dialog box. Check the Preview box so that you can see your guides draw on the page as you modify the settings in the dialog.
2. Specify whether you want to fit the guides to the page or the margins, the number of rows and columns you want, and the desired gutter width.
3. If you want to remove existing ruler guides already on the page, check the box.

Note: *this feature will only remove guides on visible layers. If you've got ruler guides you want to keep, turn off visibility for those layers, and then use Create Guides to remove the remaining visible guides.*

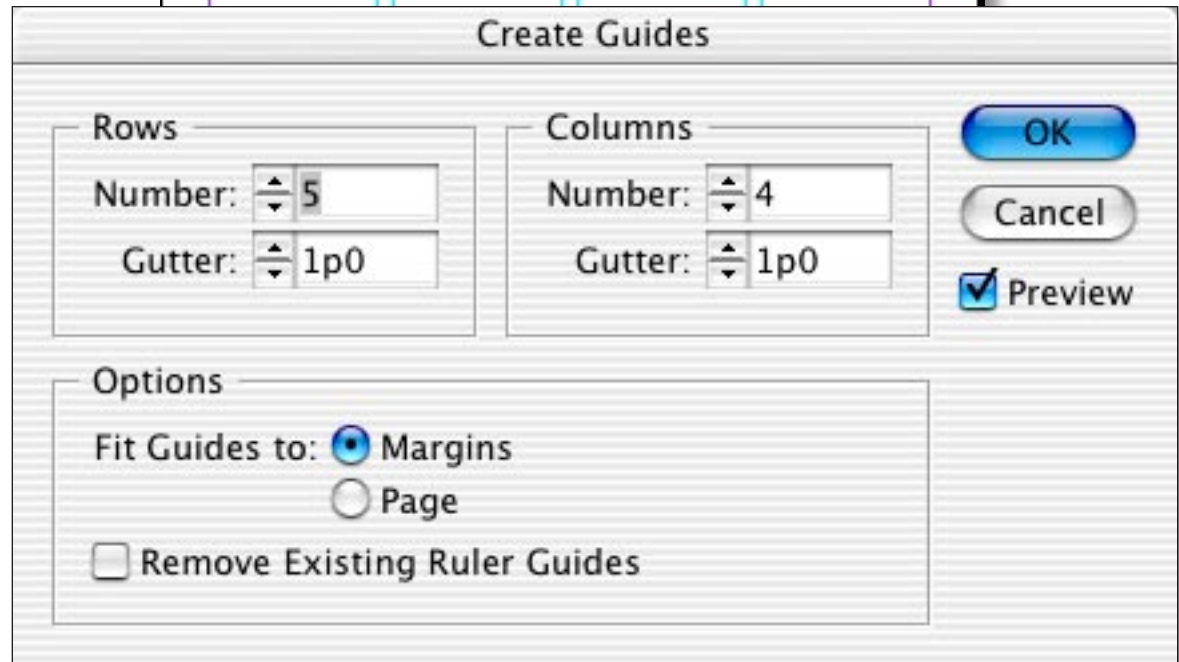
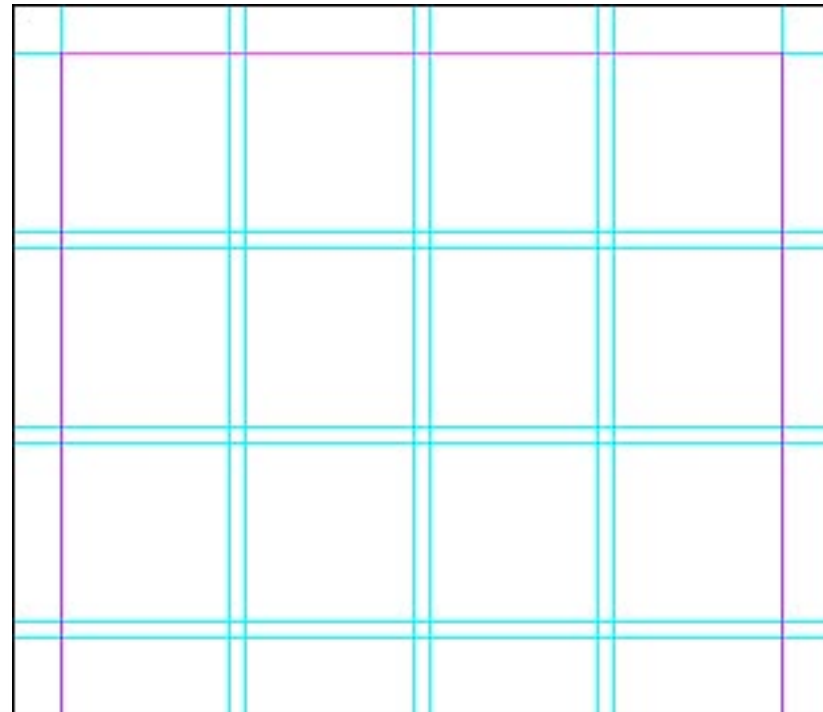

storing and placing guides using libraries

You can save sets of guides as elements in an InDesign library. This enables you to create the guides once, and then store them as reusable components for use in future layouts.

1. Select one or more guides in your layout.
2. Add guides to a library by using the Add Item command on the Library palette fly-out menu.
3. To place guides in a library on a page, use the Place Items command on the same menu. The guides will be placed the same location that the page that they had when they were created and saved into the library.

Note: unlike other objects, you can't drag and drop ruler guides from a library, because they are always placed at their saved coordinates.

